

An ecological acoustic recorder (EAR) for long-term monitoring of biological and anthropogenic sounds on coral reefs and other marine habitats

Marc O. Lammers^{a)}

Hawaii Institute of Marine Biology, University of Hawaii, 46-007 Lilipuna Road, Kaneohe, Hawaii 96744 and Joint Institute for Marine and Atmospheric Research, University of Hawaii, 1000 Pope Road, Honolulu, HI 96822

Russell E. Brainard

NOAA Fisheries, Pacific Islands Fisheries Science Center, Coral Reef Ecosystem Division, 1125 B Ala Moana Boulevard, Honolulu, Hawaii 96814

Whitlow W. L. Au and T. Aran Mooney

Hawaii Institute of Marine Biology, University of Hawaii, 46-007 Lilipuna Road, Kaneohe, Hawaii 96744

Kevin B. Wong

NOAA Fisheries, Pacific Islands Fisheries Science Center, Coral Reef Ecosystem Division, 1125 B Ala Moana Boulevard, Honolulu, Hawaii 96814

(Received 27 February 2007; revised 14 December 2007; accepted 28 December 2007)

Keeping track of long-term biological trends in many marine habitats is a challenging task that is exacerbated when the habitats in question are in remote locations. Monitoring the ambient sound field may be a useful way of assessing biological activity because many behavioral processes are accompanied by sound production. This article reports the preliminary results of an effort to develop and use an Ecological Acoustic Recorder (EAR) to monitor biological activity on coral reefs and in surrounding waters for periods of 1 year or longer. The EAR is a microprocessor-based autonomous recorder that periodically samples the ambient sound field and also automatically detects sounds that meet specific criteria. The system was used to record the sound field of coral reefs and other marine habitats on Oahu, HI. Snapping shrimp produced the dominant acoustic energy on the reefs examined and exhibited clear diel acoustic trends. Other biological sounds recorded included those produced by fish and cetaceans, which also exhibited distinct temporal variability. Motor vessel activity could also be monitored effectively with the EAR. The results indicate that acoustic monitoring may be an effective means of tracking biological and anthropogenic activity at locations where continuous monitoring by traditional survey methods is impractical.

© 2008 Acoustical Society of America. [DOI: 10.1121/1.2836780]

PACS number(s): 43.80.Ev, 43.80.Ka [MCH]

Pages: 1720–1728

I. INTRODUCTION

A significant challenge faced by many governmental and nongovernmental management and conservation agencies is the assessment and long-term monitoring of the condition of remote marine ecosystems worldwide. The widespread distribution and isolation of many habitats found along secluded coastal areas, reefs, seamounts, and insular habitats can make monitoring logistically difficult and expensive. Research cruises often result in high ship time costs and typically allow only intermittent and limited opportunities for assessing the conditions at many sites. Moored instruments capable of measuring a wide range of environmental parameters, such as surface and subsurface temperatures, salinity, wave energy, and current flow, provide measures of environmental variability but do not obtain data directly about the biological activity taking place at a location. As a result, many significant ecological events, such as disease outbreaks, episodic

infestations (e.g., harmful algal blooms, crown-of-thorn sea stars), reactions to climate change (e.g., massive coral bleaching), and the effect of storms, oil spills, and poaching often occur undetected at remote locations, complicating the interpretation of long-term monitoring data.

The application of an acoustics-based approach to monitoring may provide an important complementary method for detecting changes in the marine environment. This is because sounds present in many marine habitats can be an effective indicator of a number of biological processes, such as spawning events (Lobel, 1992; Luczkovich *et al.*, 1999; Hawkins and Amorim, 2000), courtship behaviors (Mann *et al.*, 1997), feeding (Vesluis *et al.*, 2000) competition (Johnston and Vives, 2003), and social communication among many species of fish, invertebrates, and aquatic mammals. These sounds can be detected over ranges of tens to thousands of meters, depending on the species producing them and the background ambient noise level (Mann and Lobel, 1997; Janik, 2000; Lugli and Fine, 2003; Sprague and Luczkovich, 2004). Therefore, examining the sounds occurring in remote

^{a)}Electronic mail: lammers@hawaii.edu

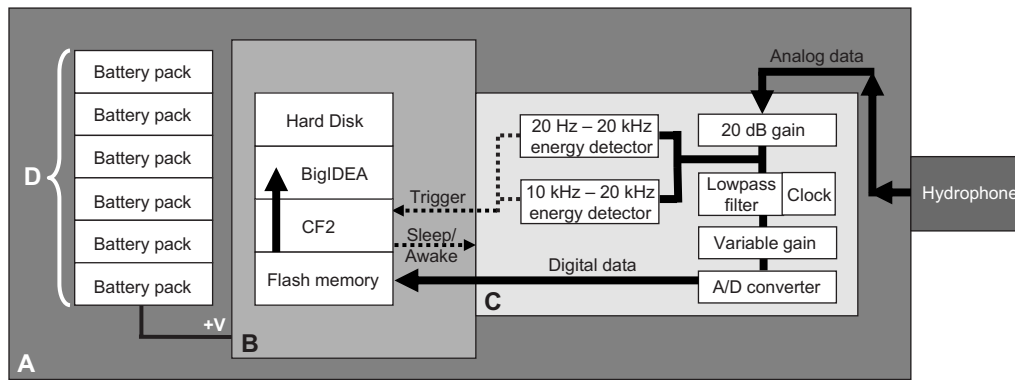

FIG. 1. A schematic representation of the EAR showing (A) the environmental interface module, (B) the central processing unit (CPU)/storage module, (C) the signal conditioning/analog-to-digital conversion (SCADC) module, and (D) the power supply module. The solid arrows (→) represent the flow of data while the dashed arrows (⇄) describe the operational relationship between the CPU/storage and SCADC modules.

marine habitats could serve as an effective proxy for tracking certain biological processes and detecting natural and changing patterns of biological activity at many locations.

Some of the most challenging habitats to monitor are coral reefs. Coral reefs are among the most biologically diverse and complex ecosystems in the world. Their diversity supports economies around the globe through a variety of commercial activities, such as tourism, fishing, and pharmaceutical production. Despite, and partly because of, their economic and cultural value, coral reefs are rapidly being degraded in many parts of the world by a variety of stressors that include pollution, over fishing, coastal development, physical disturbance, and global climate change (Wilkinson, 2002). The difficulty of managing the health of coral reefs is compounded by the fact that they can be some of the most remote habitats in the world, making them particularly prone to experiencing unobserved changes and declines.

Acoustic monitoring of coral reef habitats is a potentially fruitful approach because many animals associated with coral reefs and nearby waters are soniferous. Numerous species of coral reef fish produce sounds (Myrberg, 1981), as do several invertebrates (Johnson *et al.*, 1947). Additionally, marine mammals that either directly or indirectly interact with the neritic environment associated with coral reefs are also quite vocal (Popper, 1980). Tracking the acoustic activity level of many of these animals is therefore a promising approach for assessing patterns of change, stability, and seasonality in biological processes occurring at different trophic levels over time. This article reports on research to develop the tools needed for monitoring the ambient sounds on remote coral reefs and other marine habitats. Several examples are provided of the types of biological and anthropogenic activities that long-term acoustic monitoring can help document and follow.

II. MATERIALS AND METHODS

Recording the ambient sound field of remote marine habitats for extended periods of several months to a year or longer presents several challenges. The recording bandwidth, power consumption, and data storage capacity of the recorder are among the factors that must be considered care-

fully, as these affect or involve finite system resources. The cost of production is another important consideration. A prohibitively high price that severely restricts the number of units that can be deployed reduces the system's usefulness as a monitoring tool. Finally, software algorithms that allow for the efficient processing and interpretation of the data obtained are vital to effectively deal with the large volume of acoustic recordings produced by long-term deployments made at multiple locations.

The need for long-term data and low cost preclude an approach that involves continuous recording over a wide bandwidth. Such an approach requires vast power reserves and data storage capacity, each of which reduces the affordability of the system and adds to the engineering complexity. An approach involving periodic recording with the ability to turn "on" when signals of interest occur is more desirable from both a cost and a data management standpoint.

The Ecological Acoustic Recorder (EAR) was developed to meet these requirements. The EAR is a digital recorder based on a Persistor™ CF2 microprocessor. It is a low power system that records on a programmable duty cycle, but is also capable of responding to acoustic events that meet specific criteria.

A. Hardware

Four principal components make up the EAR hardware: the environmental interface module, the signal conditioning/analog-to-digital conversion module, the central processing unit (CPU)/storage module and the power supply module. Figure 1 shows a schematic of how the different components are integrated.

The environmental interface module consists of the recording hydrophone and the package in which the electronics are housed. The system uses a Sensor Technology SQ26-01 hydrophone with a response sensitivity of -193.5 dB that is flat (± 1.5 dB) from 1 Hz to 28 kHz. One of two housing packages manufactured by Sexton Photographics can be used, depending on the target deployment depth (Fig. 2). For deployments to less than 46 m, a 10.16-cm-diam by 60-cm-long by 0.64-cm-thick PVC tube is used that is enclosed on one end by a permanently sealed cap and on the other by an

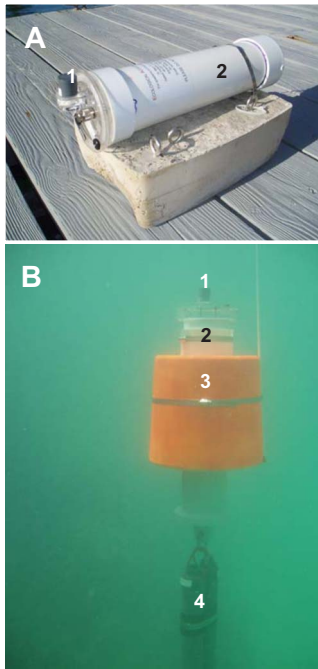

FIG. 2. (Color online) (A) The shallow water EAR showing (1) the hydrophone and (2) the PVC housing attached to a concrete anchor. (B) The deep EAR showing (1) the hydrophone, (2) the aluminum housing, (3) the syntactic foam collar, and (4) the acoustic releases attached to a sacrificial anchor (not shown).

acrylic face, on which the hydrophone is mounted. This package is typically attached to a lead or concrete anchor by divers. For deployments to 500 m, an aluminum housing is used in combination with a syntactic foam float and an acoustic release system (Sub Sea Sonics AR-60). Deep water EAR units and their releases are anchored to a sacrificial weight (typically ~ 70 kg of gravel/sand bags) using a 1 m stainless steel cable and released overboard. A topside acoustic release interrogator (Sub Sea Sonics ARI-60) is used to obtain range information to the unit and trigger the erosion of the release's burn wire. Two releases are typically used in parallel for redundancy.

The signal conditioning/analog-to-digital conversion (SCADC) module is a custom-designed circuit that amplifies and filters the input signal and then digitizes it. The analog signal is passed through a series of operational amplifier stages (MAX494, Maxim Integrated Products, Sunnyvale, CA) for amplification and then filtered using a switched capacitor filter (LTC1064-7, Linear Technology Corporation, Milpitas, CA). This provides an eighth-order low-pass filter with a cutoff frequency that is controlled by an input clock. That clock is provided by a programmable oscillator (MAX1077L-40, Maxim Integrated Products, Sunnyvale, CA). The cutoff frequency is set via software as a fractional percentage value of the Nyquist frequency, for example 80%. After being filtered, the signal is then digitized by a 16 bit analog-to-digital converter (Burr-Brown ADS8344, Texas Instruments, Dallas, TX). Recordings are first stored as raw binary files in flash memory and then periodically transferred to a hard drive (see the following).

In addition to conditioning the analog signal, the

SCADC module also includes circuitry that monitors the input signals for specific types of acoustic events. Two event-detection circuits "listen" for energy in different frequency bands through a series of op-amps (MAX494) and differential comparator stages (LP339, National Semiconductor, Santa Clara, CA). A "wideband" event detector monitors the energy in the frequency band from 20 Hz to 20 kHz, while a "high frequency" detector monitors the energy in the band from 10 to 20 kHz. Variable resistors are used to set the signal amplitude thresholds and the energy integration period that cause each circuit to send an interrupt request to the CPU, indicating the occurrence of an acoustic event. Either (or both) event detector can be programmed to operate in parallel with duty cycled recordings.

The CPU/storage module receives input from the SCADC module and controls the recording process. It is composed of the Persistor CF2 microprocessor, a 1 Gbyte compact flash card, a Persistor BigIDEA IDE adapter, and a 120 Gbyte 2.5 in. Toshiba hard disk drive. Custom-written software on the CF2 microprocessor controls the recording duty cycle, the system's power consumption and the transfer of data from flash memory to the hard disk, and monitors the event detection circuits for interrupt requests. The CF2 is accessed via a serial connection that allows a number of variables to be modified using a terminal emulation program (e.g., HYPERTERMINAL™, MOTOCROSS™). These variables include the sampling rate, the length of individual recordings, the recording period, the recording start date and time, whether to record when an event detection circuit is triggered, and other parameters related to power monitoring and the anti-alias filter cut-off frequency.

Finally, the power supply module provides the system with a continuous voltage supply. The module consists of four battery packs wired in parallel. Each battery pack is composed of seven high capacity D-cell alkaline batteries serially wired to provide 20 500 mA h of current at 10.5 V. The modular arrangement of the battery packs allows them to easily be added or subtracted according to the power consumption needs of individual deployments. Deployments requiring more than four battery packs are realized by simply lengthening the environmental interface module.

B. Power consumption

The EAR's power consumption is regulated through the CF2 microprocessor. It controls the power supply to the SCADC module and the frequency with which the hard disk drive is accessed. To minimize the latter, the CF2 monitors the number of recordings present on the compact flash card and calculates the time it will take to transfer them to the hard disk. The disk is spun up and accessed at intervals that keep the writing process from interfering with scheduled recordings. When in standby mode between recording periods, the EAR draws 0.3 mA of current when the event detection circuits are disabled and 4.0 mA if they are enabled. When recording, the unit draws approximately 70 mA, and when writing to disk it uses between 300 and 400 mA.

C. Operation

The EAR can be programmed to begin recording either immediately when powered on, or at a future date and time. The sampling rate used will depend on the target species and/or the signals of interest. Prior experience has determined that sampling at a rate of 25 kHz (providing 12.5 kHz of bandwidth) is well suited for capturing the majority of coral reef-associated acoustic signals and the sounds of motor vessels passing nearby. If higher frequency sounds are of interest, such as those produced by cetaceans, a maximum sampling rate of 64 kHz can be selected.

The recording duty cycle and duration used for a deployment must be chosen based on several factors. These include the likelihood of capturing the signal(s) of interest, the length of the deployment, the number of recordings that can be stored on the hard disk drive, and the expected power consumption. Using a duty cycle method for recording is not well suited for capturing acoustic signals and events that are very infrequent and random, but it is effective in documenting the pattern of occurrence of regularly occurring signals typical of a specific location. The approach used to collect the data presented here was to record at a 3.3% duty cycle, or once every 15 min for 30 s. This produced approximately 4.38 Gbytes of data per month and consumed about 3.54 A when no event detection was enabled (6.25 A when event detection was enabled).

Event detection can in theory be applied to capture any acoustic event with sufficient energy and lasting long enough to meet the threshold criteria set in the SCADC circuit. This capability is especially useful for detecting the occurrence of events such as vessels transiting nearby, which generally produce sustained high levels of acoustic energy for several seconds. Calls or signals produced by animals can also be automatically detected, provided their levels are sufficiently high to distinguish them from the natural fluctuations in the background ambient noise. Thus, the efficiency of event detection will be determined primarily by the signal-to-noise ratio present at a specific site.

D. Data analysis

The volume of data produced by the EAR even for short deployments makes manual analysis of all the recordings collected unfeasible. If one considers that, at a recording duty cycle of 3.3% without event detection enabled, 2880 recordings are produced over a 30 day period, it is clear that an automated analysis approach is required if long-term data are to be used as an effective and timely monitoring tool. To this end, custom algorithms were developed in MATLAB™ and in Lockheed Martin's RIPPEN™ programming environment that process the data sets automatically. Figure 3 shows a flow chart summarizing the data reduction process. Among the variables that are extracted from each recording are: the rms sound pressure level (SPL) and its variance, the number of acoustic events detected automatically, the number of short pulses with a maximum above a defined threshold, and the frequency of occurrences of specified sounds of interest.

To establish the occurrences of specific sounds, each recorded file is searched using one or more template files rep-

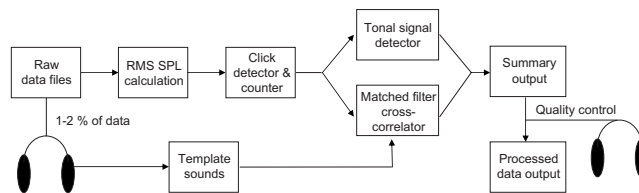

FIG. 3. A flow chart diagram summarizing the data reduction process for EAR data. A subset of data files are examined manually and template files are created of representative sounds. All data files are subjected to rms SPL calculations, a click detector and counter routine and either a matched filter analysis or a tonal signal detector or both. The summary output is checked manually to confirm the matched filter and/or tonal signal detector results.

resenting the signal of interest. Template files are obtained by visually and aurally examining approximately 1% to 2% of the data from each site and identifying discrete, repeated biological signals. Representative examples of these sounds are then used to search the database by stepping the template files through each recording and performing a cross correlation at each step. Cross-correlation matches of 0.70 (min = 0, max = 1) or greater are accepted as detections of the reference signal. A manual evaluation of this approach determined that, for stereotyped signals, it is a moderately conservative method of establishing signal occurrence, with a somewhat greater tendency for producing false negative than false positive detections. This was deemed more desirable than a liberal method that results in excessive false positive detections. For signals with higher variability, the correlation threshold can be lowered to reduce the number of missed detections.

A different method is used to detect the presence of more variable tonal sounds, such as those produced by many cetacean species and some species of fish. A short-time Fourier transform approach is applied to find consistent periods of tonal spectral peaks in each data file. These periods are then summed and reported for each recording. Data files with tonal periods in excess of 1% are manually examined to first confirm the presence of biologically related sounds and then to identify their likely origin (whale, dolphin, fish, echosounder, etc.).

E. Preliminary deployments

Test deployments of the EAR were conducted at four sites around the island of Oahu, HI. Two sites were in Kaneohe Bay (KB1, 21° 28.245 N 157° 49.585 W and KB2, 21° 26.030 N 157° 47.485 W), one in the Waikiki Marine Life Conservation District (WMLCD, 21° 15.94 N 157° 49.670 W) and one off Makua Beach (MB, 21° 31.75 N 158° 13.940 W). The KB1 site was monitored monthly for 10 day periods over a period of 1 year between December 2004 and November 2005. These deployments were conducted with the first generation of the EAR system and were limited to 10 day periods by the original system's higher power consumption. Subsequent deployments were conducted with the EAR system as described earlier. These lasted between 17 and 42 days. The deployment at the WMLCD site was between 25

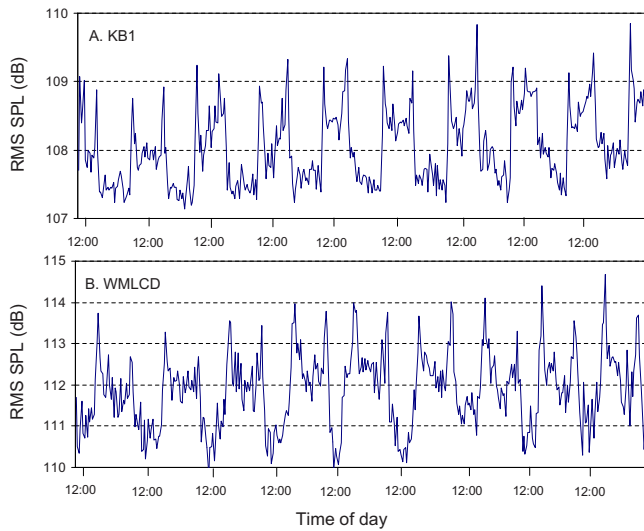

FIG. 4. (Color online) (A) Plot of snapping shrimp acoustic energy received at site KB1 from 12 to 21 December 2004. (B) Plot of snapping shrimp acoustic energy received at site WMLCD from 25 January to 2 February 2006. “12:00” represents noon on each day.

January and 10 February 2006, the deployment at MB was between 13 February and 25 March 2006 and the deployment at the KB2 site was between 21 July and 31 August 2006.

III. RESULTS

The deployments at the four sites yielded a total of 16,161 recordings. The results presented here are highlighted examples of the trends that were observed. They are not comprehensive and should be viewed only as preliminary. No specific inference relating to reef condition is intended; rather, they are presented to illustrate the utility of the EAR system as a tool to monitor temporal trends in biological and anthropogenic activity on coral reefs and other types of marine habitats.

A. KB1 deployments

Site KB1 is located on the slope of a small patch reef (200 m × 150 m) inside Kaneohe Bay at a depth of approximately 8 m. The reef is primarily dominated by large colonies of the coral species *Porites compressa*, but two other species with a significant presence are *P. lobata* and *Pocillopora meandrina*. Several species of reef fish occur at or near the site. These include members of the genera *Cheateodon*, *Dascylus*, *Scarus*, *Labroides*, *Zanclus*, *Thalassoma*, *Mulloidichthys*, *Acanthurus*, *Zebrasoma*, *Gymnothorax*, and *Abudefduf*, among others.

The predominant sound on this reef, as on all the reefs that were examined, was the “crackle” of snapping shrimp (*Alpheus sp.*). This is the summed contribution of the clicks produced by individual, benthic-dwelling shrimp rapidly closing their enlarged claw, thereby producing a collapsing cavitation bubble (Vesluis *et al.*, 2000). Figure 4(A) illustrates that this crackle has a clear, diel cyclical pattern that can be measured by plotting the averaged rms SPL of the recordings over time. This pattern exhibits two distinct fea-

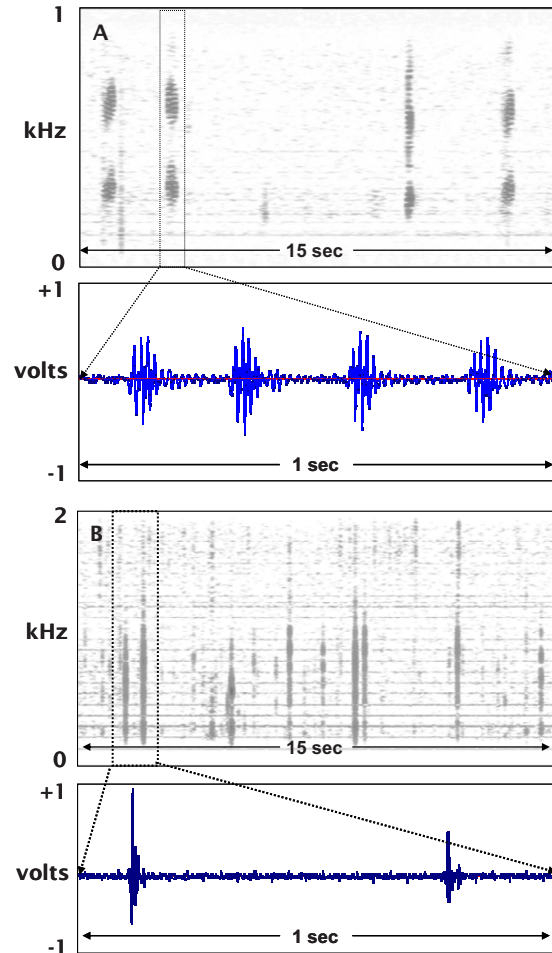

FIG. 5. (Color online) Spectrogram and wave form of signals recorded at the KB1 site from (A) *Dascyllus albisella* and (B) an unidentified species (KB1sigB).

tures. The first is a sharp increase in activity during crepuscular periods. This is represented by a nearly 2 dB rise and then drop in rms SPL levels over a 2 h period centered on sunrise and sunset. The second is a higher level of activity during daylight hours than during the night, which was consistent throughout the 1 year period that the site was monitored.

Visual and aural examination of the data revealed that up to five sounds likely originating from fish occurred with regularity at this site. The most common of these was a pulsed train shown in Fig. 5(A) known to be produced by domino damsel fish (*Dascyllus albisella*) (Mann and Lobel, 1997). This sound is thought to represent a territorial defense signal and is often heard by divers who approach a damselfish colony. It was produced significantly more during daylight hours (3.2 pulses/min) than at night (1.3 pulses/min) (One-way ANOVA, $p < 0.001$). In addition, its occurrence over the 1 year period that the site was monitored showed evidence of seasonal variability, with a sharp increase in activity noted during the month of May (Fig. 6).

The other sounds heard in the recordings could not be matched to the species producing them. The most common of these was a single, short (10 ms), pulsed signal with broadband energy between 200 and 1500 Hz, shown in Fig.

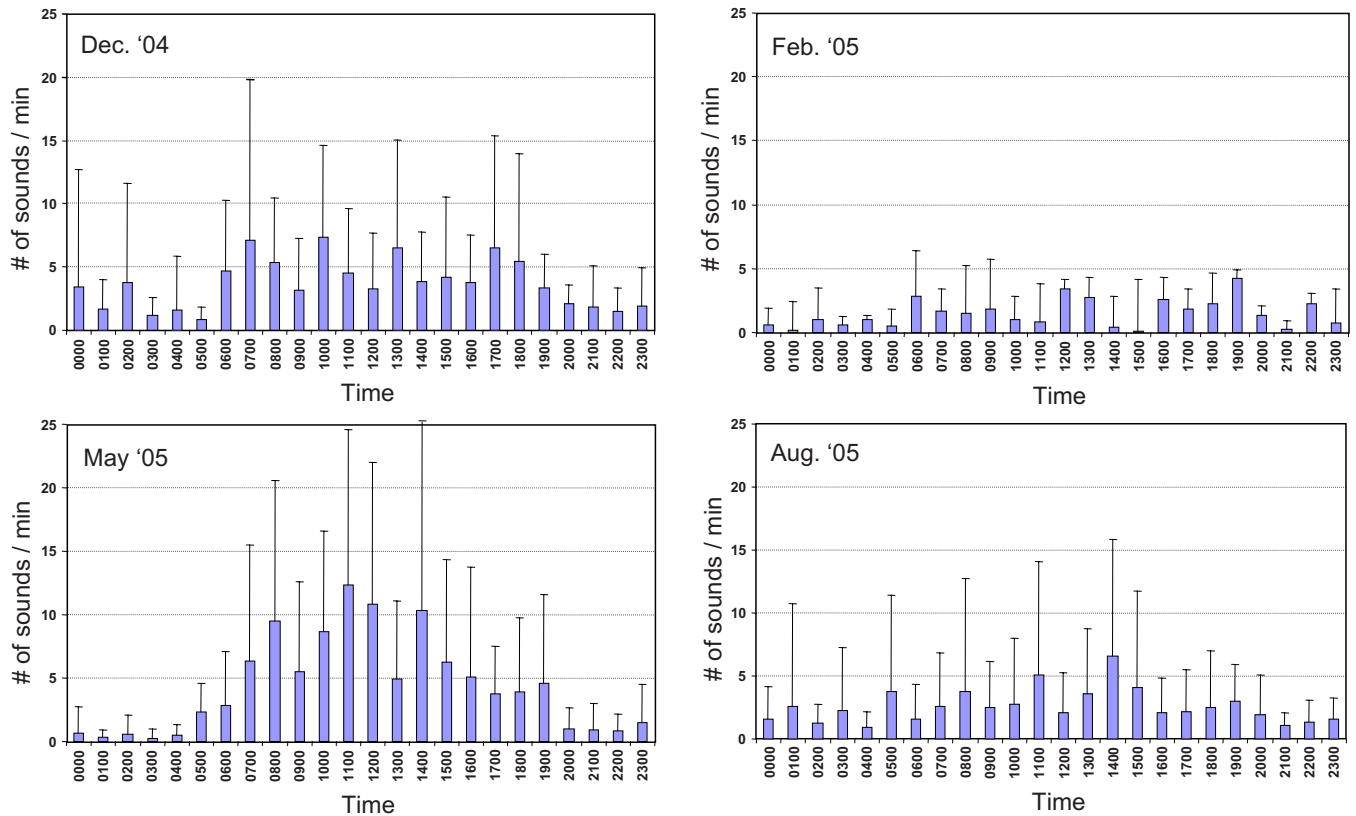

FIG. 6. (Color online) Monthly variation of *Dascyllus albisella* signals recorded at site KB1 averaged over the deployment period showing an increase in signaling during the month of May.

5(B) and termed KB1sigB. It also exhibited a distinct diel pattern of occurrence. However, unlike the damselfish pulse train, this signal occurred almost exclusively at night. More specifically, it was produced primarily about 1 h before sunrise and 1 h after sunset. Moreover, the time of maximum occurrence closely followed the change in day length between December and May (Fig. 7).

B. WMLCD deployment

The WMLCD site is characterized by mostly uncolonized basaltic rock reef. Despite limited coral cover, protection from fishing has promoted a moderately high level of fish biodiversity in the area. Many of the taxa described for the KB1 site are also found here in addition to others, such as *Rhinecantus*, which is commonly observed at the site. The EAR was deployed at a depth of approximately 6 m.

As in Kaneohe Bay, the snapping shrimp sound field exhibited a clear diel trend. A sharp increase in activity occurred both at sunrise and at sunset. This pattern was even more pronounced here than at the KB1 site, with a rise of nearly 4 dB occurring during crepuscular periods relative to daytime levels [Fig. 4(B)]. In contrast to KB1, however, overall snapping shrimp noise levels were higher during nighttime hours than during the day by approximately 2 dB. In other words, the diel trends at the two locations were reversed.

Manual examination of the data set revealed that nine distinct sounds, presumably from fish, occurred with regularity at this site. These could not be identified to the species,

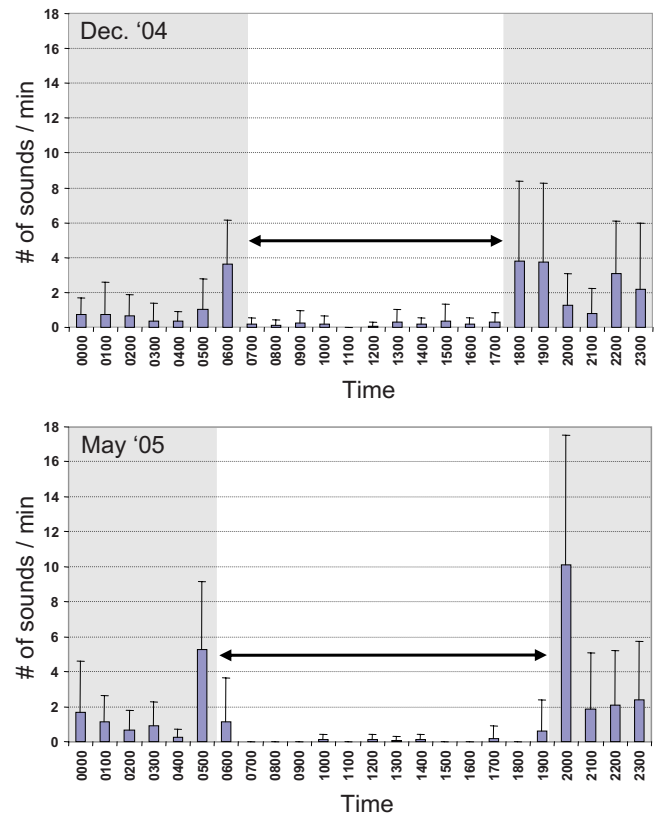

FIG. 7. (Color online) The occurrence of the KB1sigB signal as a function of time of day averaged over the deployment period. The top panel shows its occurrence in December 2004 and the lower panel shows its occurrence in May 2005. The shaded areas indicated nighttime. Note the correspondence between the shift in acoustic activity and the change in the length of day.

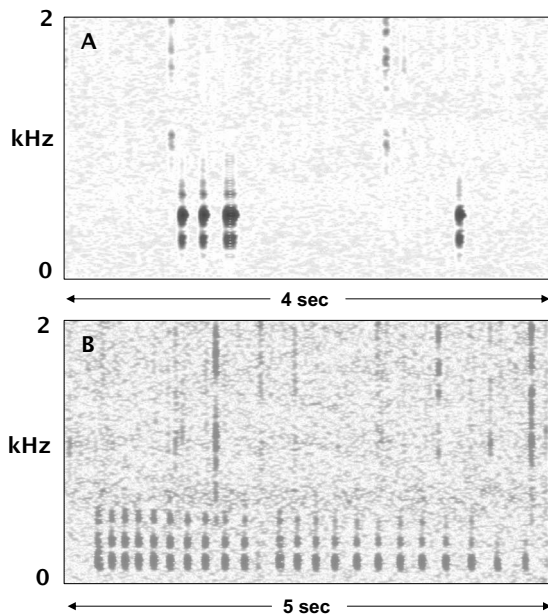

FIG. 8. Spectrograms of the two most common fish sounds recorded at the WMLCD site, (A) WMLCDsigA and (B) WMLCDsigD.

but all exhibited diel patterns of occurrence. The most common was a 30 ms pulse with a peak frequency of 500 Hz shown in Fig. 8(A) (WMLCDsigA). Although presumably produced by a different species of fish, its temporal pattern of occurrence was strikingly similar to that of the KB1sigB sound, with distinct peaks in occurrence during presunrise and postsunset periods. Another very common sound was WMLCDsigD, shown in Fig. 8(B). This 25 ms pulse with peak frequency around 170 Hz occurred rarely during daylight hours, was somewhat more common at night, and was most frequent for about 1 h just after sunset.

C. MB deployment

The MB EAR was not deployed on a coral reef but rather on a large stretch of sand at a depth of approximately 15 m. The site was chosen to gauge the effectiveness of the EAR as a tool for documenting the presence of cetaceans in an area over time. The waters off Makua Beach are well known as a daytime spinner dolphin (*Stenella longirostris*) resting area (Lammers, 2004). In addition, wintering humpback whales (*Megaptera novaengliae*) commonly occur nearby during the period between January and April. Both species are acoustically active and regularly produce social signals in the recording frequency band of the EAR (Lammers *et al.*, 2003; Au *et al.*, 2006).

Dolphin whistles and/or clicks were detected 203 times out of 3841 recordings. The presence of dolphins was recorded on 29 out of the 41 days that the EAR was deployed. The occurrence of dolphins at the Makua Beach area was not uniform throughout the deployment period. Rather, detections were few and sporadic during the initial part of the deployment, relatively consistent for a period of approximately 2 weeks during the second half of the deployment, and nearly absent during the last several days [Fig. 9(A)]. In addition, some clear diel trends were observed in the produc-

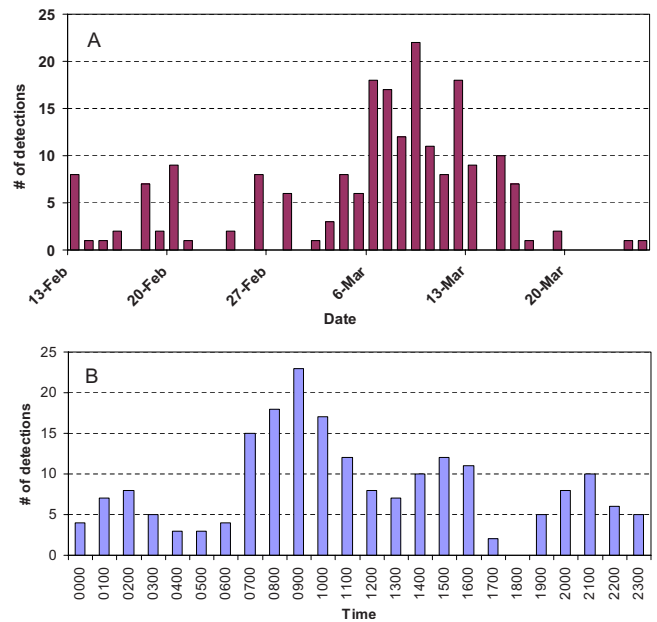

FIG. 9. (Color online) (A) The occurrence of recordings with dolphin signals at the MB site over the course of the deployment period. (B) The occurrence of recordings with dolphin signals as a function of the time of day averaged over the deployment period.

tion of sounds [Fig. 9(B)]. The most active period was during the morning, with a peak at around 0900 h. Acoustic activity was considerably reduced during the middle of the day before increasing and peaking again at around 1500 h. The fewest detections occurred during the hours just prior to sunset and sunrise.

D. KB2 deployment

Site KB2 is located on the slope of the reef adjacent to Moku'O'Loe (Coconut) island in Kaneohe Bay at a depth of approximately 5 m. This site was chosen primarily because of its proximity to one of the bay's small boat channels. The primary objective of this deployment was to gauge the EAR's ability to be triggered in response to passing vessel traffic.

Five hundred seventy-four vessels were detected during the deployment, or an average 14.35 vessels per day (s.d. = 5.58). Significantly more vessels were detected on weekend days (19.58/day, s.d. = 6.33) than during weekdays (12.11/day; s.d. = 3.36) ($P=0.002$; two-sample t -test). In addition, Fig. 10 shows that nearly all vessel traffic was detected between the hours of 0700 h and 2100 h, with the peak in traffic occurring at 1600 h.

IV. DISCUSSION

The results presented indicate that the EAR and the automated data analysis algorithms provide an effective combination of tools for documenting the temporal patterns of a wide range of acoustic signal types. The first test deployments revealed that the EAR is a useful instrument for recording long-term patterns of biological sound production on coral reefs and other marine habitats. In addition, the event

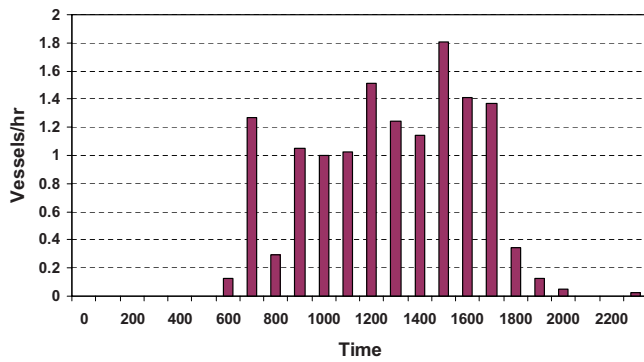

FIG. 10. (Color online) The occurrence of motor vessels at site KB2 as a function of time of day averaged over the deployment period.

detection capability of the system proved effective in documenting the occurrence of anthropogenically produced sounds, such as vessel engine noise.

It is evident from the two deployments on coral reefs that, not only are there numerous sounds present on reefs, but that their occurrences tend to follow well-defined, temporal patterns that are tied to physical variables, such as day/night cycles, changes in day length, and seasons. This relationship with the physical environment is of significance because it indicates that the ambient sound field is in fact influenced by abiotic factors experienced by the habitat. This finding lends support to the hypothesis that sounds on a reef will reflect ecologically significant changes in conditions. Some evidence for this already exists. [Watanabe *et al.* \(2002\)](#) provided the first indication that snapping shrimp activity is tied to changes in water temperature and dissolved oxygen concentrations. This relationship needs to be investigated further before inferences can be made on reef conditions, but the finding raises the intriguing possibility that events such as temperature-induced coral reef bleaching might be accompanied by measurable changes in the snapping shrimp sound field.

The peak in activity of damselfish sounds recorded at the KB1 site in May was coincident with the beginning of their breeding season ([Randall, 1996](#)). Whether the increase was related to spawning behavior, more territorial defense, or a change in some other activity is not presently known. However, the fact that a change was measured further validates the approach of long-term, periodic sampling of the sound field as a means of documenting trends occurring on time scales of days, months, or seasons.

The EAR's ability to document the presence of cetaceans adds to its value as an ecological monitoring tool. Cetaceans are higher trophic level consumers than most of the fish and invertebrate species occurring on coral reefs. Therefore, their presence or absence from an area has implications with respect to certain resources occurring there. Spinner dolphins in Hawaii, for example, are known to forage on a community of mesopelagic organisms that migrates vertically and horizontally toward shore each night ([Benoit-Bird and Au, 2003](#)). Not surprisingly, their signals were recorded at night, as this probably reflected their nocturnal return toward shore with their prey. Of note, however, is their rather episodic pattern of occurrence at the MB site, suggesting that

prey occurrence and distribution might be heterogeneous with respect to time and space. Long-term passive acoustic monitoring of spinner dolphins over a broader area could therefore be a useful tool for gaining new insights into both spinner dolphin distribution and also the temporal and spatial occurrence of a community of prey that sustains not only cetaceans, but also tunas, billfishes, and bottomfishes ([Benoit-Bird *et al.*, 2001](#)).

Finally, the EAR's demonstrated ability to trigger in response to vessel engine noise makes it a useful tool for natural area managers concerned with monitoring the amount of legal and/or illegal vessel activity in conservation districts, parks, reserves, and sanctuaries. This is especially the case for locations where direct monitoring is either not feasible or only intermittently possible, such as many remote islands and atolls. However, it should be noted that the system's ability to detect vessels will be limited by the trigger thresholds that are set, which in turn will be determined by the natural ambient noise level. Thus, quieter environments will allow setting lower thresholds, which will improve the system's ability to detect far-off vessels and those with quieter engines. Follow-up work with the EAR system will be directed at better defining the range of vessel detection under different ambient noise conditions.

In summary, passive acoustic monitoring of coral reef and other marine habitats appears to be a fruitful means of gaining new insights into both biological and anthropogenic activities at locations of interest. Moreover, the EAR takes its place alongside other passive acoustic recorders that have been developed in recent years for monitoring marine sounds ([Calupca *et al.*, 2000](#); [Duncan *et al.*, 2000](#); [Fox *et al.*, 2001](#); [Wiggins, 2003](#); [Wiggins *et al.*, 2005](#)). Ongoing work with the EAR will continue to investigate long-term patterns of sound production on coral reefs and other marine habitats and will explore further their link with the ecosystem's condition.

ACKNOWLEDGMENTS

The authors thank Bob Herlien for his contributions to the design of the EAR circuit and software, Ken Sexton for the design of the system's environmental interface module, and Dave Lemonds and Rey Nakamura with Lockheed Martin for their contribution to the RIPPEN-based analysis software. The authors are also grateful to Sara Stieb, who assisted with processing much of the preliminary EAR data. In addition, Paul Nachtigall provided valuable logistical assistance for the work presented. Funding support was provided by the National Oceanic and Atmospheric Administration's (NOAA) Coral Reef Conservation Program as part of the Reef Assessment and Monitoring Project and also the State of Hawaii Department of Land and Natural Resources' Division of Aquatic Resources. Use or mention of any of the commercial products described in this publication does not constitute an endorsement by NOAA Fisheries or any other Federal agency. This is HIMB publication No. 1302.

Au, W. W. L., Pack, A. A., Lammers, M. O., Herman, L. M., Deakos, M., and Andrews, K. (2006). "Acoustic properties of humpback whale song," *J. Acoust. Soc. Am.* **120**, 1103–1110.

- Benoit-Bird, K. J., and Au, W. W. L. (2003). "Prey dynamics affect foraging by a pelagic predator (*Stenella longirostris*) over a range of spatial and temporal scales," *Behav. Ecol. Sociobiol.* **53**, 364–373.
- Benoit-Bird, K. J., Au, W. W. L., Brainard, R. E., and Lammers, M. O. (2001). "Diel horizontal migration of the Hawaiian mesopelagic boundary community observed acoustically," *Mar. Ecol.: Prog. Ser.* **217**, 1–14.
- Calupca, T. A., Fristrup, K. M., and Clark, C. W. (2000). "A compact digital recording system for autonomous monitoring," *J. Acoust. Soc. Am.* **108**, 2582.
- Duncan, J. A., Cato, D. H., Thomas, F., and McCauley, R. D. (2000). "The development of a compact instrument for the measurement of biological sea noise," *J. Acoust. Soc. Am.* **108**, 2584.
- Fox, C. G., Matsumoto, H., and Lau, T. K. A. (2001). "Monitoring Pacific Ocean seismicity from an autonomous hydrophone array," *J. Geophys. Res.* **106**, 4183–4206.
- Hawkins, A. D., and Amorim, M. C. P. (2000). "Spawning sounds of the male haddock, *Melanogrammus aeglefinus*," *Environ. Biol. Fish.* **59**, 29–41.
- Janik, V. M. (2000). "Source levels and the estimated active space of bottlenose dolphin (*Tursiops truncatus*) whistles in the Moray Firth, Scotland," *J. Comp., Psych.* **186**, 673–680.
- Johnson, M. W., Everest, A., and Young, R. W. (1947). "The role of snapping shrimp (*Crangon* and *Synalpheus*) in the production of underwater noise in the sea," *Biol. Bull.* **93**, 122–138.
- Johnston, C. E., and Vives, S. P. (2003). "Sound production in *Codoma ornata* (Girard) (Cyprinidae)," *Environ. Biol. Fish.* **68**, 81–85.
- Lammers, M. O. (2004). "Occurrence and behavior of Hawaiian spinner dolphins (*Stenella longirostris*) along Oahu's leeward and south shores," *Aquat. Mamm.* **30**, 237–250.
- Lammers, M. O., Au, W. W. L., and Herzing, D. L. (2003). "The broadband social acoustic signaling behavior of spinner and spotted dolphins," *J. Acoust. Soc. Am.* **114**, 1629–1639.
- Lobel, P. S. (1992). "Sounds produced by spawning fish," *Environ. Biol. Fish.* **33**, 351–358.
- Luczkovich, J. J., Sprague, M. W., Johnson, S. E., and Pullinger, R. C. (1999). "Delimiting spawning areas of weakfish, *Cynoscion regalis* (family Sciaenidae), in Pamlico Sound, North Carolina using passive hydroacoustic surveys," *Bioacoustics* **10**, 143–160.
- Lugli, M., and Fine, M. L. (2003). "Acoustic communication in two freshwater gobies: Ambient noise and short-range propagation in shallow streams," *J. Acoust. Soc. Am.* **114**, 512–521.
- Mann, D. A., Bowers-Altman, J., and Rountree, R. A. (1997). "Sounds produced by the striped cusk-eel *Ophidion marginatum* (Ophidiidae) during courtship and spawning," *Copeia* **1997**, 610–612.
- Mann, D. A., and Lobel, P. S. (1997). "Propagation of damselfish (Pomacentridae) courtship sounds," *J. Acoust. Soc. Am.* **101**, 3783–3791.
- Myrberg, A. A., Jr. (1981). "Sound communication and interception in fishes," in *Hearing and Sound Communication in Fishes*, edited by A. R. Popper and R. R. Fay (Springer, Berlin), pp. 359–426.
- Popper, A. N. (1980). "Sound emission and detection by Delphinids," in *Cetacean Behavior: Mechanisms and Functions*, edited by L. M. Herman (Wiley, New York), pp. 1–52.
- Randall, J. E. (1996). *Shore Fishes of Hawaii* (University of Hawaii Press,), 216 pp.
- Sprague, M. W., and Luczkovich, J. J. (2004). "Measurement of an individual silver perch (*Bairdiella chrysoura*) sound pressure level in a field recording," *J. Acoust. Soc. Am.* **116**, 3186–3191.
- Vesluis, M., Schmitz, B., von der Heydt, A., and Lohse, D. (2000). "How snapping shrimp snap: Through cavitating bubbles," *Science* **289**, 2114–2117.
- Watanabe, M., Sekine, M., Hamada, E., Ukita, M., and Imai, T. (2002). "Monitoring of shallow sea environment by using snapping shrimps," *Water Sci. Technol.* **46**, 419–424.
- Wiggins, S. M. (2003). "Autonomous acoustic recording packages (ARPs) for long-term monitoring of whale sounds," *Trans. Inst. Min. Metall., Sect. C* **37**, 13–22.
- Wiggins, S. M., Grasha, C., Hardy, K., and Hildebrand, J. (2005). "High-frequency Acoustic Recording Package (HARP) for long-term monitoring of marine mammals," *J. Acoust. Soc. Am.* **117**, 2525.
- Wilkinson, C. (2002). *Status of Coral Reefs of the World: 2002* (Australian Institute of Marine Science), 378 pp.